

24° konus / 24° konus  
 24° cone end / 24° cone end  
 24° Anschluss / 24° Anschluss

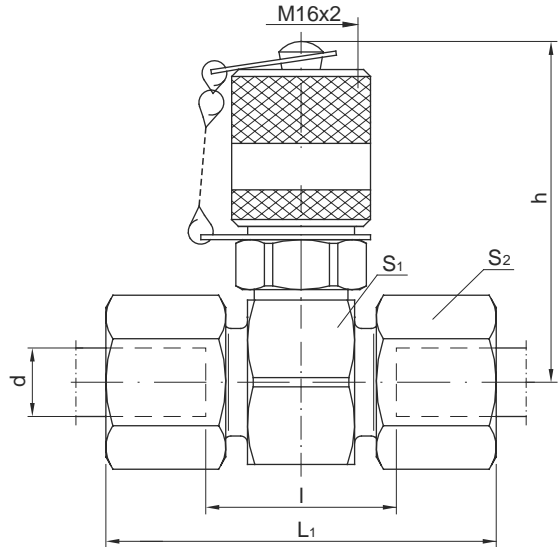

Red Series Reihe	PN	Cev Øspoljašnji Tube o.d. Rohr Ø aussen	L	l	h ≈	S <sub>1</sub>	S <sub>2</sub>	Oznaka Partno. Bezeichnung
L	315	06	51	21	49	24	14	<b>JMP 20/06-L</b>
		08	51	21	49	24	17	<b>JMP 20/08-L</b>
		10	53	23	49	24	19	<b>JMP 20/10-L</b>
		12	53	23	50,5	27	22	<b>JMP 20/12-L</b>
		15	55	25	52	30	27	<b>JMP 20/15-L</b>
		18	57	24	53	32	32	<b>JMP 20/18-L</b>
	160	22	61	28	55	36	36	<b>JMP 20/22-L</b>
		28	61	28	57,5	41	41	<b>JMP 20/28-L</b>
		35	69	26	60	46	50	<b>JMP 20/35-L</b>
		42	71	27	64,5	55	60	<b>JMP 20/42-L</b>
T	630	06	55	25	49	24	17	<b>JMP 20/06-T</b>
		08	55	25	49	24	19	<b>JMP 20/08-T</b>
		10	57	24	49	24	22	<b>JMP 20/10-T</b>
		12	57	24	49	24	24	<b>JMP 20/12-T</b>
		14	63	27	50,5	27	27	<b>JMP 20/14-T</b>
	400	16	63	26	52	30	30	<b>JMP 20/16-T</b>
		20	69	26	55	36	36	<b>JMP 20/20-T</b>
		25	75	27	57,5	41	46	<b>JMP 20/25-T</b>
		30	81	28	60	46	50	<b>JMP 20/30-T</b>
	315	38	89	29	64,5	55	60	<b>JMP 20/38-T</b>

L1 = kada je navrtka u pritegnutom stanju

L1 = approx. figures with tightened nut

L1 = wenn die Überwurfmutter im angezogenen Zustand ist